

# SAFETY EQUIPMENT

## 2024 CATALOG

 Canadian Edition



**NORTH AMERICAN LEADER  
IN MANUFACTURING ROOFING EQUIPMENT**



[grizzlyase.com](http://grizzlyase.com)



1-888-325-9953  
orders@grizzlyase.com

## STRONGER, SAFER, SMARTER.

### Keep your team safe, improve your job site.

At **GRIZZLY ASE**, safety is our daily commitment. In this catalog, we present you with the best products on the market. From our ultra-flexible mobile anchor systems to our robust and customizable guardrails, as well as our secure access bridges and modular barriers, each piece of equipment has been rigorously tested to meet the strictest standards and guarantee optimal protection on all your job sites. These products combine safety, performance, and adaptability to meet all your needs.



All the prices listed in this catalog are in \$CAD.

# HERCULES MOBILE ANCHORING SYSTEM

## UNIQUE EFFECTIVE DESIGN AND NO COUNTERWEIGHTS NEEDED

A mobile anchoring system for fall protection on flat roofs and similar structures, tailored to maximize productivity, safety, and ease of use through innovative design and advanced features.

### HERCULES ANCHORING SYSTEM (1000 lbs)

#### OPTIONS

861 000	Hercules Anchoring System	\$7 990
861 000 SW	Hercules Anchoring System with solid wheels	\$8 100

#### QUEBEC MODEL

860 000	Hercules Anchoring System (For Quebec only)	\$7 725
860 000 SW	Hercules Anchoring System with solid wheels (For Quebec only)	\$7 900



#### Suitable for the following types of roofs:

Built-up asphalt and gravel,  
Modified bitumen system,  
Single-ply system such as  
fully adhered TPO, PVC, EPDM,  
Elastomeric membrane, and  
Wood (deck), mechanically  
fixed plywood.

### READY TO USE



**Durable, portable, safe and easy to  
operate by a single person.**

**Leave it on the roof for easy  
maintenance, all year long!**

#### DIMENSION

Length	82" (with the handle down) 120" (with the handle up)
Width	31"
Height	35" (with the wheels up) 43" (with the wheels down)
Platform Size	46 x 31"
Ground Clearance	0" to 7.5"
Tires	18 x 8.50 x 8, 4 ply rating,
Weight	1250 lbs.

#### CAPACITY

Fall Arrest	2 workers*
Travel Restraint	4 workers*
Tires	815 lbs. capacity each

\*Refer to the operator manual for more detailed information.

CSA Certified	Z259.16-04
OSHA Compliant	1926.502
	1910.140
	1910.66
ANSI Certified	Z359.18-2017



# GUARD RAIL SYSTEM

Fully compliant with OSHA Fall Protection guidelines, the ASE Guardrail System provides excellent fall protection around roof edges, openings and other obstructions.



## RAIL SYSTEM\*

- Section off the job site into zones to easily organize work and personnel.
- Warn workers of impending dangers such as hazardous materials or falls.
- Disassemble and relocate Guardrail sections quickly and easily.
- Meets and exceeds ANSI and OSHA requirements.
- Can be left on roof as permanent barrier (or permanent fencing).

### OPTIONS

107 100	Rail System - 5 ft.	\$ 600
107 101	Rail System - 7.5 ft.	\$ 650
107 102	Rail System - 10 ft.	\$ 685
107 107	Based only + Pins	\$ 395
108 012	Rail Only - 5 ft.	\$ 205
108 014	Rail Only - 7.5 ft.	\$ 255
108 016	Rail Only - 10 ft.	\$ 290

\*A rail system includes only 1 rail and 1 base.



## GUARD RAIL BASE TRANSPORTER

A 2 wheeled dolly that is equipped with 400 x 4.80 wheels to move guard rail bases easily.

- Lightweight and easy to transport
- 110 lbs carrying capacity
- Simple fulcrum mechanism
- Protect workers' health and wellbeing

107 010	Guard Rail Base Transporter	\$ 680
---------	-----------------------------	--------

# SAFETY GUARD POST

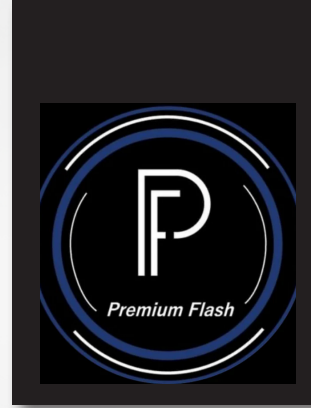

## Easy Installation, Lasting Protection

The Single Adjustable Post and Two-in-One Adjustable Post with Gravity lock are welded steel posts for parapets, open edges, and flat surfaces. Both posts comply with **OSHA**, **CSA regulations**, the **Ontario Building Code** and the **Quebec Safety Code for the construction industry**. They can be mounted on any vertical surface, such as a parapet wall, header beam, floor joist, wall stud, or roof truss. The Two-in-One post offers additional versatility by allowing for mounting on flat roofs.



### SINGLE BASE

### TWO IN ONE BASE

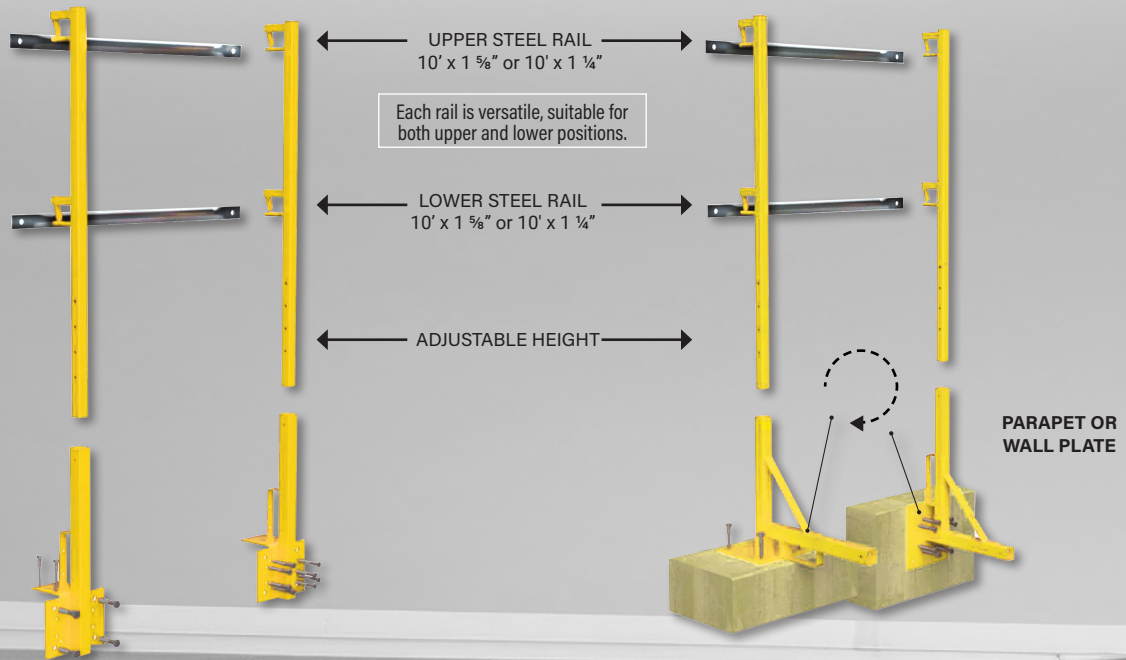

## SAFETY GUARD POST

These safety guard posts are designed to provide physical barriers and enhance safety in various environments. They are equipped with adjustable heights to accommodate different needs and are constructed with wood stud rings for secure attachment. The posts feature both upper and lower steel rails for added protection.

### OPTIONS

20-PF-GC-1	① Guardrail post adjustable - SIMPLE BASE	\$208
20-PF-GC-2	② Guardrail post adjustable - 2 IN 1 BASE	\$229
20-pf-GC-BARP	③ Galvanized steel guardrail bar 10 x 1-1/4	\$41
20-pf-GC-BARG	④ Galvanized steel guardrail bar 10 x 1-5/8	\$78

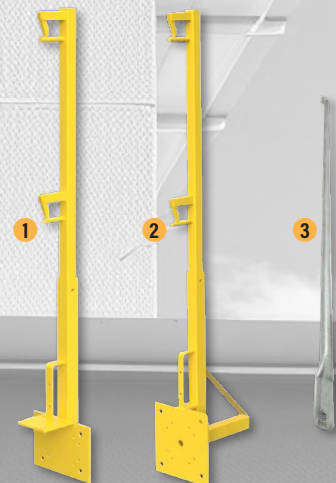

# FALLBAN CABLEGUARD SYSTEM Roof Fall Protection



With just a few simple parts installed, your roof can be OSHA compliant, safe for anyone on the roof whether under construction or installed as a permanent system on an existing building.

### LABOR SAVINGS

**FallBan** allows "Roofers" to stay fully focused on the job at hand, without having to dodge lanyards or be restricted by harnesses. They have found eliminating the need for workers to be tied off greatly increases productivity on the roof.

For many years the **FallBan** system has been the preferred choice, for its ease of use, multiple configurations, and efficiency.

Now, **FallBan 2** offers a rail, cable, or hybrid-rail/cable barrier system with the same benefits as the previous cable-only system.

**OSHA, SOR and USACE** compliant, fast and easy setup, and 100% approval by safety inspectors for over 15 years.

### Create your own Fall Protection System!



Rail barrier

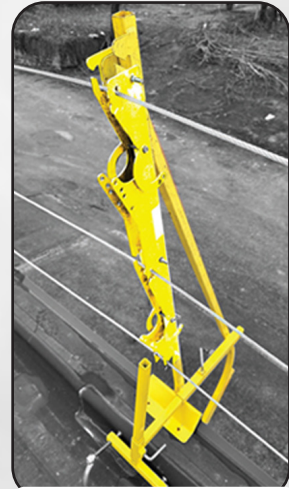

Cable barrier

Or both!

### FEATURES

**Versatile:**

Supports cable, rail, and hybrid barriers.

**Easy to Install:**

Quick setup with minimal tools.

**Flexible:**

Customizable spacing for various applications.

**Durable:**

Built to last, with some systems still in use after 19 years.

**Compatible:**

Works with both new and old FallBan parts.

**Portable:**

Compact storage and transportation solution.

**Efficient:**

No ballast needed, maximizing workspace.

**Space-Saving:**

Small footprint for a given barrier length.

**Adaptable:**

Compatible with different roof types.



# FALLBAN KITS

FALLBAN 2* 80 ft. Quick Corner Kit	Qty
1 FallBan 2 Stanchions	6
2 Stanchion to Wall Rests	6
3 FallBan 2 Mid Braces	5
4 Diagonal Braces	4
5 Cable Pullers	2
6 Stanchion Support plate	6
7 Cable 250' Roll	1
8 Flag line 100 FT	1
9 Cable Corner Rollers	6
10 Wooden Storage Pallet	1

\* Does not include Extension Bars, Parapet Clamps or hard rail accessory equipment. Call for price.

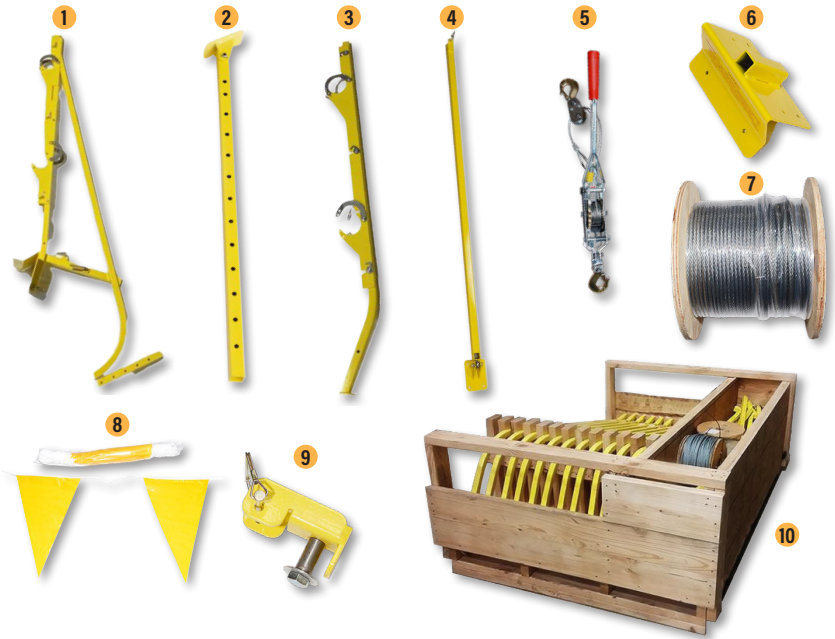

FALLBAN BASIC STRAIGHT RUN KITS include:							
ITEM#	KIT SIZE	COMPLETE STANCHIONS	MID BRACES	DIAGONAL BRACES	ANCHOR PLATES	CABLE	FLAG LINE
FB2-80	80'	2	5	4	2	250'	100'
FB2-100	100'	6	5	2	2	300'	100'
FB2-200	200'	11	10	2	2	600'	200'
FB2-400	400'	21	20	2	2	1200'	400'
FB2-500	500'	26	25	2	2	1500'	500'

Basic Kits can be adapted to standard flat or gravel stop edges or gutter edges.

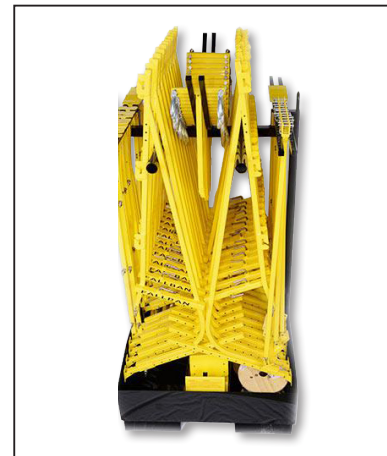

FALLBAN PREMIUM KITS include:											
ITEM#	KIT SIZE	COMPLETE STANCHIONS	MID BRACES	DIAGONAL BRACES	ANCHOR PLATES	CABLE	FLAG LINE	CORNER ROLLER ASSEMBLIES	EXTENSION BARS	PARAPET CLAMPS	DIAGONAL BRACE SWIVELS
FB2-P-100	100'	6	5	4	2	300	100	3	6	6	1
FB2-P-200	200'	11	10	8	2	600	200	12	11	11	1
FB2-P-400	400'	21	20	10	2	1200	400	12	21	21	2
FB2-P-500	500'	26	26	12	2	1500	500	15	26	26	2

Premium Kits can be adapted to standard flat or gravel stop edges, gutter edges, corners (both inside and outside) parapet walls (of a variety of widths) and roof overhangs.

100' - 200' set will include a wooden shipping container. Sets larger than 200' will include a steel FallBan Storage Pallet.

**Call your distributor for price.**



# ROOF GUARD AND FALL PROTECTION

PREMIUM PRODUCTS.  
BUILT FOR A LONG-TERM INVESTMENT.



## SAFETY FOR ALL USERS

Delta Prevention offers innovative and versatile fall protection systems. The guardrails are 100% free-standing, made with aluminum pipes that resist rust and deterioration, and our patented bases are crafted from recycled rubber.

Delta Prevention roof fall protection products are certified by an independent engineering firm and comply with **CNBC** and **OSHA** standards.

Eco-responsible products 100% designed and manufactured in Canada.

**Aluminum pipes that resist rust and deterioration.**

**Certified by an independent engineering firm and comply with CNB and OSHA standards.**

**Our certified turnkey solutions are tailored to your standard needs.**



**10 year Warranty**





### VSS COMPACT SAFETY GUARDRAIL

VSS Compact guardrail system with two 5-foot returns. Ideal for areas with limited space.

	1	2	3
ITEM#	#GR-COM01	#GR-COM02	#GR-COM03
GUARDRAIL (FT.)	10'	20'	40'
PALLET DIMENSION	48" x 42" x 25"	48" x 42" x 25"	48" x 42" x 30"
PALLET WEIGHT	480 lbs	600 lbs	830 lbs
BUNDLE DIMENSION	120" x 6" x 6"	120" x 6" x 6"	120" x 10" x 8"
BUNDLE WEIGHT	50 lbs	60 lbs	100 lbs
\$ PRICE	\$3436	\$4422	\$6350

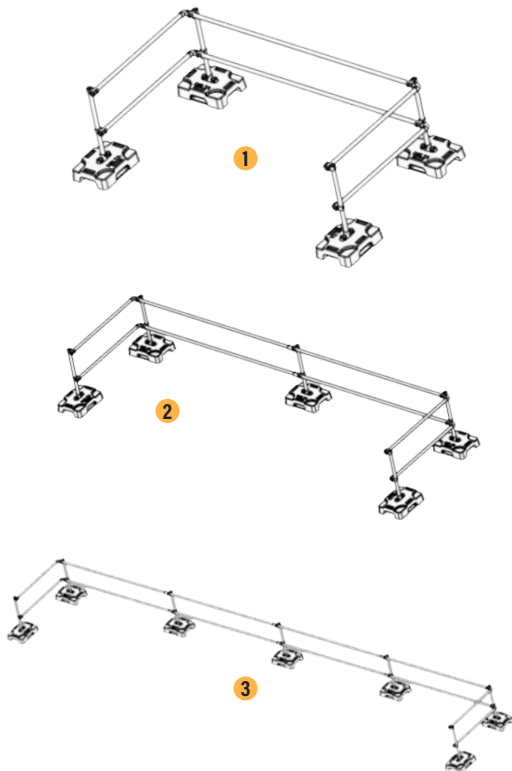

### VSS COMPACT CORNER GUARDRAIL

VSS Compact corner guardrail system with two 5-foot returns. Ideal for securing the corner of a building when space is limited.

	1	2	3
ITEM#	#GR-COM04	#GR-COM05	#GR-COM06
GUARDRAIL (FT.)	10' - 10'	10' - 20'	20' - 20'
PALLET DIMENSION	48" x 42" x 25"	48" x 42" x 25"	48" x 42" x 30"
PALLET WEIGHT	600 lbs	725 lbs	830 lbs
BUNDLE DIMENSION	120" x 6" x 6"	120" x 6" x 6"	120" x 10" x 8"
BUNDLE WEIGHT	60 lbs	80 lbs	100 lbs
\$ PRICE	\$4474	\$5438	\$6402

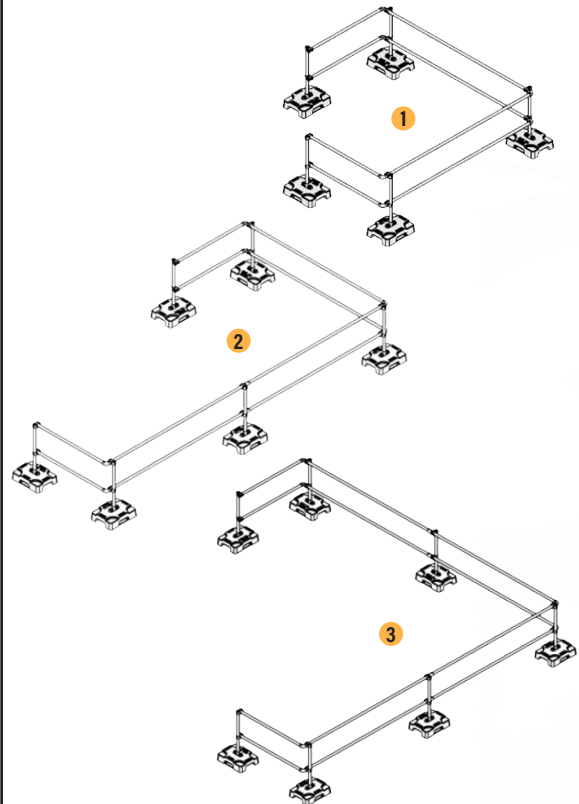



**HATCH SAFETY SYSTEMS**

The roof hatch guardrail protects access to the hatch and provides handholds to increase safety entering or exiting the ladder. This guardrail also prevents falls into the hatch when it is left open.

	1	2
ITEM#	#GR-HAT01 (Standard)	#GR-HAT02 (Oversized)
DIMENSION	36" x 48"	104" x 52"
PALLET DIMENSION	48"x24"x30"	48" x 40" x 25"
PALLET WEIGHT	220 lbs	200 lbs
BUNDLE DIMENSION	N/A	120" x 6" x 6"
BUNDLE WEIGHT	N/A	60 lbs
\$ PRICE	\$3239	\$3632

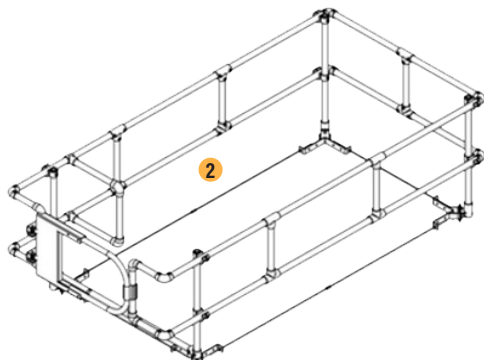
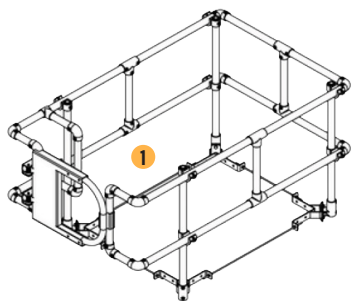

**LADDER STABILIZER SYSTEM**

Delta Prevention's patented ladder stabilizer system is designed to create safe access to roofs accessible by an extension ladder.

ITEM#	#GR-LAD01
PALLET DIMENSION	54" x 42" x 40"
PALLET WEIGHT	400 lbs
\$ PRICE	\$4734

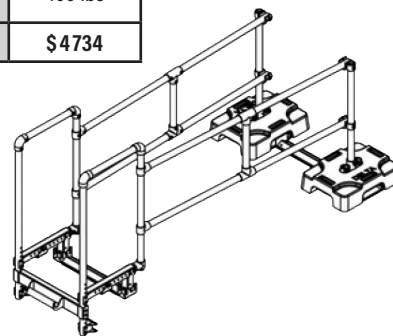

**SELF-CLOSING SAFETY GATE**

Self-closing gates are the best solutions to prevent falls in access points such as stairs or ladders by closing areas to workers or pedestrians.

ITEM#	#GR-GAT01
PACKAGING	1 box (30" x 8" x 23") - 17 lbs
\$ PRICE	\$957

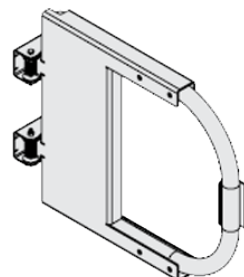

**VSS CLASSIC GUARDRAIL**

Linear configuration to secure between a minimum of 10 feet up to your entire perimeter without any return.

ITEM#	#GR-CLA01
GUARDRAIL (FT.)	10'
PALLET DIMENSION	48" x 42" x 24"
PALLET WEIGHT	500 lbs
BUNDLE DIMENSION	120" x 4" x 4"
BUNDLE WEIGHT	30 lbs
\$ PRICE	\$2941

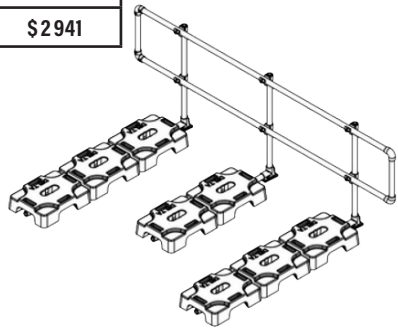

**CORNER CLAMPS**

ITEM#	#GR-CON01
PACKAGING	Set of 2
\$ PRICE	\$53

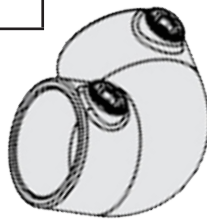

**VARIABLE ANGLE CLAMPS**

ITEM#	#GR-CON02
PACKAGING	Set of 2
\$ PRICE	\$87



**INSTALLATION**

**LIGHTWEIGHT ALUMINUM RAILING**

This makes installation easier and faster.



**ONE TOOL NEEDED**

You will only need a impact wrench and a 5/16".

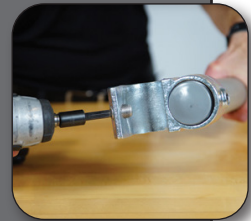

**QUICK INSTALLATION**

Installing a 20-foot VSS Compact system takes less than 15 minutes.



**LIGHTWEIGHT ALUMINUM RAILING**

This makes installation easier and faster.



SAV11092024



Distributed by:



**NORTH AMERICAN LEADER  
IN MANUFACTURING  
ROOFING EQUIPMENT**

8650, Rue du Creusot,  
Saint-Léonard, Qc H1P 2A7  
grizzlyase.com • 1 888 325.9953

