

FRANSYL

POLYBASE R+ HYBRID SYSTEM

MONOLITHIC PANEL FOR ACCELERATED WATERPROOFING ROOF SYSTEM

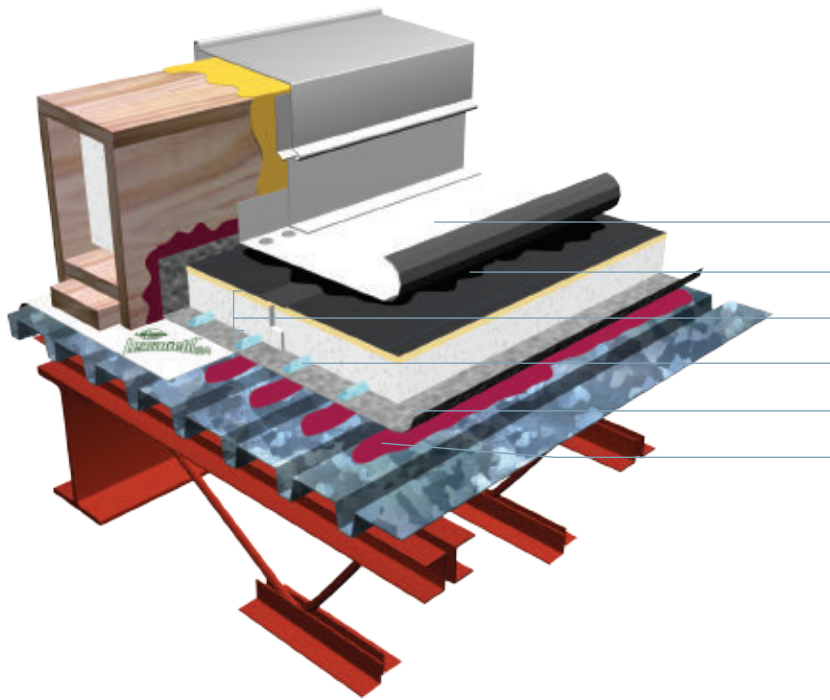

- Lexcan Fleece-Backed membrane
- Lexcor Lexstick CA adhesive
- Fransyl Polybase R+ S
- Lexcor Adphalt adhesive
- Lexcor Permaste Stick SA Vapour Barrier
- Lexcor Multigrip adhesive and primer

ADVANTAGES

- 🏠 Fransyl offers a 30 year warranty for parts and services for this system*
- 🏠 Insulation thermal value warranty of minimum 35 years
- 🏠 Take off "a two-layer system" a dual membrane system
- 🏠 Polybase R+ monolithic panel
- 🏠 Meets or exceeds requested R-Value
- 🏠 Advantageous thermal value
- 🏠 No temporary sealant required after Polybase R+S panel application
- 🏠 Fast and easy installation
- 🏠 Increases contractor productivity
- 🏠 Achieves Novoclimat insulation levels
- 🏠 Flameless, no asphalt adhesive, Odour free
- 🏠 Lightweight assembly

ACKNOWLEDGMENT



*Some conditions apply

T. 450.477.4423

1.800.363.2307

FRANSYL.COM

POLYBASE R+ HYBRID SYSTEM

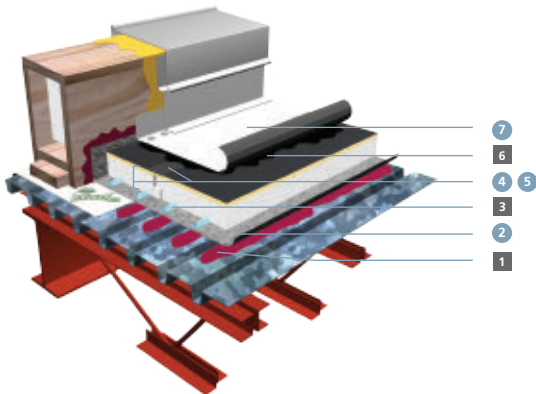

Date: _____

Project's name: _____

Address: _____

Deck: wood concrete steel other: _____

Building: Area(roof): _____ ft²

Height / number of stage(s): _____

POLYBASE R+ HYBRID SYSTEM MATERIAL OPTION

Composition down to up	Attachment/Adhesion	Material
Vapor barrier	1 <input type="checkbox"/> Lexcor Multigrip primer and adhesive <input type="checkbox"/> Lexcor Adphalt adhesive	2 <input type="checkbox"/> Lexcor Permaste <input type="checkbox"/> Lexcor Permaste Ultra-R <input type="checkbox"/> Lexcor Permaste Stick
Underlayment / Support panel / Flat insulation*	3 <input type="checkbox"/> Lexcor Adphalt adhesive <input type="checkbox"/> Mechanical fastening	4 <input type="checkbox"/> Fransyl Polybase R+ S _____ in 5 <input type="checkbox"/> Overlapping tape required for transverse joints
<i>Optional: Slope insulation</i>	N/A	<input type="checkbox"/> Fransyl Bizolon insulation _____ in
Cap sheet	6 <input type="checkbox"/> Lexcor Lexstick CA adhesive	7 <input type="checkbox"/> Hi-Flex EPDM Lexcan membrane (45 or 60 mil) <input type="checkbox"/> TPO Hi-Tuff Lexcan membrane (45 or 60 mil)

*For any additional slope or counterslope insulation, contact your Fransyl representative to obtain the appropriate option for your project.

Any modification to the system, including adhesives, primers and accessories, must be approved by Fransyl Ltd. Any modification without Fransyl's authorization will automatically void the warranty.

Note: Fransyl Ltd reserves the right to alter, without notice, the composition and conditions of use of systems and materials.

To obtain a quote for the composition of the system chosen above and the information below, send this document at infodevis@fransyl.com

Load weight

by ft²

R-Value

Budget price

by ft²

Note(s)

