



# VSS SAFETYLINE PERMANENT WARNING LINE

The VSS SafetyLine is a warning line system used to delineate a safe working area away from fall hazards. The VSS SafetyLine is 100% compliant with the OSHA and provincials permanent warning line standards.



## FEATURES

- Permanent delineation of a safety perimeter
- Modular: can be combined with Delta Prevention guardrails to secure the entire roof at a low cost
- Scalable: can be converted into a guardrail
- Freestanding: 100% without penetration
- Quick and easy installation
- Complies with OSHA, RSST and other provincials permanent warning line standards
- Compliance report included
- 10-year warranty

## MAIN COMPONENTS



Weighted base clamp



Nylon-coated steel cable and high visibility flag



Recycled rubber base



Solid mounting with carabiners

## THE IDEAL ADDITION TO DELTA PREVENTION GUARDRAILS

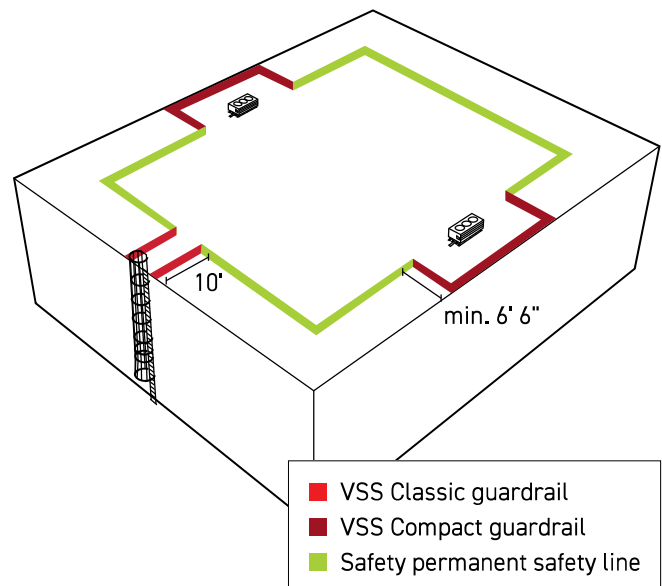

# TYPES OF INSTALLATION

## RSST - QUEBEC STANDARDS

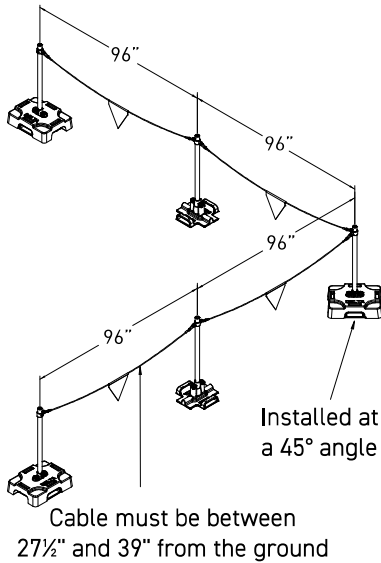

## OSHA - CANADA/USA STANDARDS

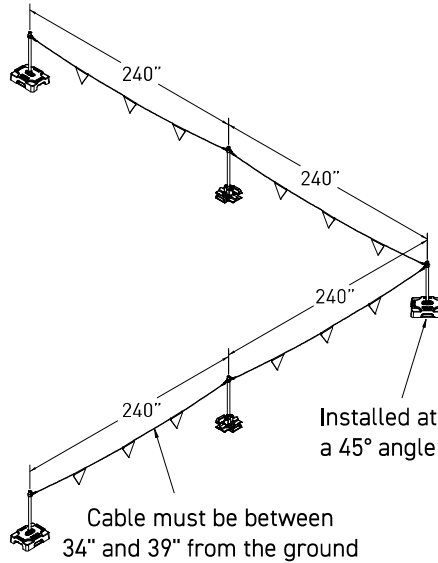

# TYPES OF CONNECTION

### TYPE G

The warning line is connected to a guardrail or wall anchor at both ends. A rubber counterweight must be added at each corner and positioned at 45°.

### TYPE S

The warning line is connected to a guardrail or wall anchor at one end only. A rubber counterweight must be added at:

- the non-connected end.
- each corner and positioned at 45°.

### TYPE N

The warning line is not connected to any end. A rubber counterweight must be added at:

- both ends.
- each corner and positioned at 45°.

# TECHNICAL SHEET

	RSST - Quebec Standards	OSHA - Canada/USA Standards
Maximum distance between poles:	96"	240"
Maximum cable height allowed:	39" from the ground	39" from the ground
Minimum cable height allowed:	27 1/2" from the ground	34" from the ground
Cable - Material:	steel, yellow nylon coating	steel, yellow nylon coating
Cable - Diameter:	1/2"	1/2"
Flag - Material:	yellow nylon	yellow nylon
Maximum distance between each flag:	72"	72"
Counterweight:	50 lb/base	50 lb/base
Counterweight - Material:	recycled rubber, galvanized cast iron with rubber mat	recycled rubber, galvanized cast iron with rubber mat
Tubing and posts:	Anodized aluminum 6061-T6	Anodized aluminum 6061-T6
Outside diameter:	1,9"	1,9"
Fittings - Material:	galvanized steel	galvanized steel
Hardware - Material:	stainless steel	stainless steel
Tightening Torque:	30 lb/ft (CL201: 20 lb/ft)	30 lb/ft (CL201: 20 lb/ft)
Use:	Permanent, temporary	Permanent, temporary
Design patent:	#162620	#162620
Warranty:	10 year	10 year
Complies with:	RSST: 354.1	OSHA: 1926.502(f)

# COMPONENTS



### Cable clamp

Terminates the cable after it has been cut to the correct length.

#ITEM: DAA27-01

Material: galvanized steel



### Double connector

This dual connector connects two straight sections of a warning line.

# ITEM: GA167-01

Material: galvanized steel



### 90° Connector

This connector connects two warning line sections and creates a 90° corner.

# ITEM: GA168-01

Material: galvanized steel



### Simple connector

This connector is used at the beginning and end of each permanent warning line. It can be installed on an independent vertical pole or on a Delta Prevention guardrail section.

# ITEM: GA173-01

Material: galvanized steel